



## The Effect of Eco-Friendly Packaging on Purchase Intention with Consumer Perception as an Intervening Variable

Megia Esvandiari<sup>1</sup>, Marcellia Susan<sup>1</sup>, Hendrati Dwi Mulyaningsih<sup>1</sup>, Muhardi<sup>1</sup>, Dede R Oktini<sup>1</sup>, Nunung Nurhayati<sup>1</sup>

<sup>1</sup>Universitas Islam Bandung, Indonesia

Received: Oct 8, 2023

Revised: Oct 27, 2023

Accepted: Nov 11, 2023

Online: Dec 20, 2023

### Abstract

The increasing use of plastic water bottles has exacerbated the global plastic waste crisis. Eco-friendly packaging is the concept of reducing and recycling plastic packaging waste. AQUA carried out this concept with Danone, who launched the AQUA Life product. This study aimed to determine the direct and indirect effects of eco-friendly packaging on the purchase intention of AQUA Life products through consumer perception and to analyze descriptively how eco-friendly packaging, consumer perception, and purchase intention of AQUA Life products. The analysis technique in this study uses Path Analysis to determine the role of consumer perception in mediating eco-friendly packaging on the purchase intention of AQUA Life products. The results showed that descriptive analysis for eco-friendly packaging, consumer perception, and purchase intention for AQUA Life products received good responses. \]And it was found that the magnitude of the indirect effect of eco-friendly packaging on purchase intention was more significant than the direct effect. This means that consumer perception as an intervening variable significantly influences eco-friendly packaging on purchase intention. The research results are expected to help the company add other features, such as the reuse idea for consumers, and reconsider product selling prices. To directly increase purchase intention, the company should pay attention to factors that influence consumer purchasing intentions, such as increasing the popularity of products.

**Keywords** *Eco-Friendly Packaging; Consumer Perception; Purchase Intention; Path Analysis*

### INTRODUCTION

Plastic bottle packaging waste used for drinks is one of the most significant contributors to plastic waste because since 1975, Indonesians' drinking habits have changed from boiled water to water packaged in plastic. Data from the Indonesian Plastic Industry Association (INAPLAS) and the Central Statistics Agency/ Badan Pusat Statistik (BPS) quoted from the Indonesian Information Portal website in 2019 shows that plastic waste (including plastic bags, plastic straws, single-use plastic bottles, and sachet packaging) in Indonesia reached 64 million tons per year. A total of 3.2 million tons of this is plastic waste that is thrown into the sea. Generally, trash in the ocean is carried and follows the flow of river water. This will, of course, pollute the environment and damage the ecosystem.

Society in today's modern era has a wasteful lifestyle. Brands are starting to be more competitive, and one of the strategies to convince consumers to buy a product is through the packaging. The marketing mix consists of 7 P + is an extension of the popular 4P analysis (Product, Price, Promotion, and place), along with 3P (People, Process, and physical Evidence) of service marketing, as well as additional P of Packaging (Cameron, 2015). AQUA dominates the bottled drinking water

### Copyright Holder:

© Megia, Marcellia, Hendrati, Muhardi, Dede, Nunung (2023)  
Corresponding author's email: megiaesvandiari@gmail.com

### This Article is Licensed Under:



market share in Indonesia; this is shown in Figure 1 based on data taken from Tempo. co

The high level of public consumption is different from the awareness of disposing of waste wisely. Passion for the environment is a moral issue, but people often find it challenging to understand the environmental impact of the everyday decisions they have made. At the same time, the responsibility for the waste of consumable packaging is not only on the product manufacturers but also on consumers as end users.

Eco-friendly packaging, or Green Packaging Design, has principles such as packaging can be recycled, packaging is made from recycled materials, packaging can be reused, and packaging is made not using hazardous materials (Santoso & Fitriyani, 2016). The solution for Eco-Friendly Packaging is no more complex than using recyclable or biodegradable materials. Everything from the upstream to downstream of the packaging materials and processes of production of the packaging must be considered. Many packaging are claimed to be Eco-Friendly Packaging. However, many ordinary people need to perceive this term better. Eco-friendly packaging does not mean that once the material is thrown away, it will merge with other waste on the soil and not harm the environment (Sri Julianti, 2014).

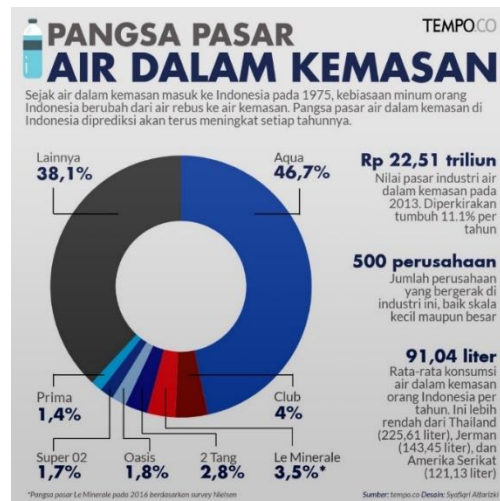

Figure 1. Bottled Drinking Water Market Share in Indonesia  
Source: Tempo. co

No longer used packaging can be reused or recycled before it becomes waste (Sri Julianti, 2014). However, most consumers do not need to learn how to use it. Information facilities that can explain the use of packaging to consumers are needed so that ordinary people can behave responsibly towards the environment. In research conducted by Magnier & Crie in 2015 regarding the ecological signals of packaging related to the signals displayed by brands to show the environmental friendliness of the packaging. There are three ecological cues obtained from respondents through discourse and images, divided into three subcategories: structural, graphic, and informational. Moreover, with this study, we will conduct descriptive analysis and test the effect of eco-friendly packaging cues on consumer perceptions and purchase intention.

The trend of consumer behavior towards an environmentally friendly attitude has increased (Geeta Rani, 2017). Consumers are increasingly concerned about the environment and want to participate actively (Guerra, 2019). Today's consumers are savvy; they usually read the product information on the packaging before buying to find out the product's benefits, how to use it, and so on. It is the right choice to make packaging a communication medium to provide information to consumers about how to use packaging and the importance of this to the environment, such as motivating consumers to reuse used packaging for various purposes, which in turn can encourage consumers to repurchase. Eco-friendly designed packaging can enable brands to build a competitive advantage (Magnier & Crié, 2015).

Perception is one of the various factors that influence consumer choices in buying a product. Consumers who are interested in a product usually will make purchases of that product. However, how people act is influenced by their perception of a particular situation. Perceptions of product performance and consumers' ability to make judgments depend highly on the intrinsic attributes that concern consumers (Krisnanda & Nurcaya, 2019). In general, consumer awareness consists of consumer perceptions and reactions. Consumer awareness is an understanding and an intention to make a purchase. Besides influencing purchase intention, consumer awareness of the use of environmentally friendly products can also help preserve the environment (Santoso & Fitriani, 2016). Manufacturers must know what factors can make purchase intentions for environmentally friendly products.

By the Regulation of the Minister of Environment and Forestry of the Republic of Indonesia Number P.75/MENLHK/SETJEN/KUM.1/10/2019 concerning "Road Map for Reducing Waste by Producers". This regulation stipulates that producers in the manufacturing sector, which includes the food and beverage industry, the consumer goods industry, and the cosmetics and personal care industries that produce goods that use packaging, must implement waste reduction through waste reduction, recycling, and reusing.

Following these regulations, this research will focus on products with Eco-Friendly Packaging, which has the concept of reducing and reusing packaging waste by AQUA with Danone, who launched AQUA Life, through innovative bottle packaging made from 100% recycled plastic and 100% recycled. This innovation manifests the tagline #BijakBerplastik Danone-AQUA movement through waste collection, consumer education, and packaging innovation. AQUA Life was first launched in Bali at the end of 2018 and later launched in Jakarta in 2019. This is a sign that AQUA is realizing its commitment. The significant consumer perception of packaging with an environmentally friendly concept and its effect on purchase intention.

The research will be focused on the city of Bandung because, based on data obtained from the Indonesian Central Agency for Environmental Statistics (Badan Pusat Statistik/BPS) 2021, the estimated production of inorganic waste per day in Bandung (2020) reached 566.26m<sup>3</sup> (BPS, 2021: 221-222). The problem is that the percentage of the volume of waste transported in Bandung is relatively low when compared to other cities, namely Jakarta and Semarang, so there is a risk that waste that is not transported will accumulate and pollute the environment.

Table 1. Data on Production and Volume of Waste Transported per Day

City	Estimated waste production per day (m <sup>3</sup> )	The volume of waste transported per day (m <sup>3</sup> )	Percentage of waste transported (%)
<b>DKI Jakarta</b>	7.164,53	6.872,18	95,92
<b>Bandung</b>	1.600,00	1289,00	80,56
<b>Semarang</b>	5.248,00	4645,00	88,50

Source: Indonesian Central Agency for Environmental Statistics (2021:221)

Based on the problems described, research will be carried out on the effect of Eco-Friendly Packaging on purchase intention with consumer perception as an intervening variable (Study on AQUA Life product in Bandung). Hopefully, this research will be helpful for the company/manufacturer who follows government regulations regarding the "Waste Reduction Roadmap by Producers." It can provide a reference for further research, especially regarding Friendly Packaging.

The hypothesis of this research is:

H1: Eco-friendly packaging has a positive effect on consumer perception

H2: Consumer perception has a positive effect on purchase intention

H3: Eco-Friendly Packaging directly Affects Purchase intention

H4: Eco-friendly packaging affects purchase intention indirectly through consumer perception.

### **LITERATURE REVIEW**

The marketing mix consists of elements of all variables that the company can control to satisfy its target customers (Lotte et al., 2023). A product can fail in the market for the simple reason that most customers do not have the time or energy to think about the advantages or disadvantages of the product they place in their shopping cart, so they rely on shortcuts to make purchasing decisions, such as quality, product appearance, and packaging excellence. Packaging is an inseparable part of a product, especially in sustainable development for marketing conception. The importance of packaging has caused some academic researchers and marketing practitioners to consider it an element of the marketing mix (Alhamdi, 2020).

Packaging is an indispensable component in the supply chain, especially for food or beverage products, because it functions as protection from contamination, the external environment, mechanical damage during transportation, or other things that can have a negative impact on product quality (Pal & Hadush, 2019, p. 22). Appropriate packaging is a marketing tool directly connected to consumer attraction and serves as a communication medium between producers and consumers. Packaging is a creative design that links shape, structure, material, image color, typography, and design elements with product information to market the product. Meanwhile, the function of packaging is to wrap, protect, release, store, identify, and differentiate a product on the market (Firmansyah, 2019, p. 176).

### **Eco-Friendly Packaging**

Transparent display is needed to distinguish products in general and products with a sustainable concept (Van den Elzen, J. 2016). This difference is, of course, displayed through the product packaging. The results of research conducted by Magnier & Crie in 2015 regarding ecological cues in packaging are related to the signals displayed by brands to indicate the environmental friendliness of the packaging. There are three ecological cues obtained from respondents through discourse and images divided into three subcategories: structural, graphic, and informational.

This is supported by the results of further research conducted by Krah, Todorovic, & Magnier, L. in 2019, namely, packaging that displays sustainable or environmentally friendly concepts communicated through structural, graphical, and informational cues will positively affect consumer perceptions. From statements regarding Eco-Friendly Packaging obtained from various sources, it can be concluded that it is indicated through packaging materials manufacturing processes (manufacturing technology) for environmental efficiency and sustainable packaging strategies without ignoring its primary function as product protection. Eco-friendly packaging can be a company strategy to display product superiority amidst business economic competition so that it becomes attractive to consumers.

Dimensions and indicators of Eco-Friendly Packaging communication, among others:

1. Structure (Magnier & Crié, 2015); have concept:
  - Reduction - reduction of excess packaging, → Reduce
  - Material (recyclable, recyclable, from renewable sources), → Recycle
  - Reusability - by reusing packaging → Reuse
2. Graphic: Display colors, designs, or images. (Magnier & Crié, 2015; and, Krah, S., Todorovic, T., & Magnier, L., 2019)
3. The claim contains two things, as follows:
  - Emotional claims containing environmental messages (Brouwers, 2018)
  - Informative/ rational claims regarding the packaging used (Brouwers, 2018; Krah, S., Todorovic, T., & Magnier, L., 2019)

### **Consumer Perception**

Perception is how individuals select, organize, and interpret certain stimuli (Sekarlaranti & Junaedi, 2013). The definition of perception, according to experts, namely Deshpande, Farley, and Webster (1993), contained in the book by Setiadi (2019), is the process by which stimuli are selected,

---

organized, and interpreted. Consumer perception can be described in two ways: psychological factors that influence buying behavior and how individuals interpret information received from the environment about products (Shafiquzzaman et al., 2018).

Perceptual dimensions and indicators that are appropriate in this study include:

1. Consumer interpretation of the information received (Shafiquzzaman et al., 2018) indicates that consumers have an interpretation of the product information submitted.
2. Dimensions of Product Features (Features). Products have features that competitors do not own/and other products have indicators, namely, consumers think that the products displayed have advantages over other products (Arianto, 2020)
3. The Dimension of Perceived Quality has an indicator. Namely, consumers think that the product displayed has reasonable quality assurance (Arianto, 2020)

### **Purchase Intention**

Purchase intention is the tendency to buy a brand and is generally based on the suitability of purchase motives with brand attributes or characteristics that can be considered; purchase intention can also be defined as a situation where consumers tend to buy certain products under certain conditions (Veybitha et al., 2021). Intention is defined as the part that motivates a behavior so that it characterizes how high a person desires to try. In consumer intentions, purchase intention is an indicator that shows consumers' desire to make purchases in the future (Yusuf, 2021).

From the explanation above, the dimensions of consumer purchase intention in this study are:

1. The tendency to buy a brand,
2. The tendency to buy because of certain conditions.
3. Someone's desire to try.
4. Price

Purchase intention indicators are explained in several components such as (Picaully, 2018):

1. Interest in finding information about products,
2. Considering buying,
3. Interested in trying,
4. Desire to have a product.

### **METHODOLOGY**

The type of research used in this study is verification. The verification method is used to find out and test the truth of the hypothesis by using statistical calculations to answer the following problem: How much effect does Eco-Friendly Packaging have on consumer perception and its implications for purchase intention directly and indirectly? Identify the path that causes a specific variable to affect other variables. To the hypothesis proposed in this study, suitable statistics for this research use path analysis. Path analysis is a statistical method used to model the causal relationship between several variables in a model. This method helps understand the extent to which these variables affect each other and how they impact other variables (Sarwono, 2011). The Path analysis shows which path is the most appropriate and short for an independent variable to the last dependent variable (Sugiyono, 2007). The path analysis model is used to analyze the pattern of relationships between variables to find out the direct or indirect influence of an independent variable (Eco-Friendly Packaging - X) on the dependent variable (Purchase Intention - Y) through an intervening variable (Consumer Perception - Z), different from regression data analysis which only influences directly. (Krisnanda & Nurcaya, 2019). Path analysis allows researchers to analyze more complex models that cannot be done by multiple linear regression. The Path Analysis model can be seen in Figure 2.

This study aimed to see and test the effect of Eco-Friendly Packaging on purchase intention directly and the indirect effect of Eco-Friendly Packaging on purchase intention through consumer perception.

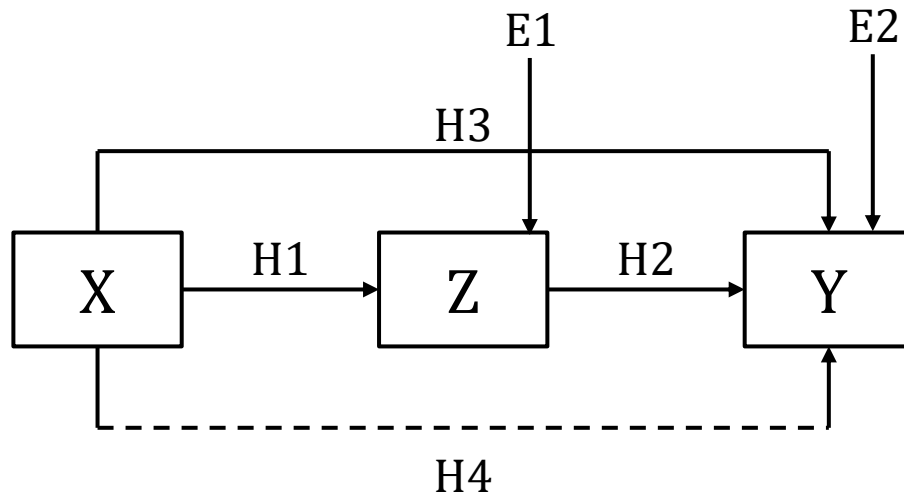

Figure 2. Path Analysis Model

Source: Created by researchers based on the variables used

This study uses Consumer perception as an intervening variable because it plays a vital role in explaining the relationship between Eco-friendly Packaging as an independent variable and Purchase Intention as the dependent variable. Intervening variables are variables between the independent and dependent variables in a causal model and function as a bridge to connect the two variables. Consumer perception can change the impact of the Eco-friendly Packaging variable on the Purchase Intention variable. By including consumer perception as an intervening variable in the analysis, researchers can understand more deeply the paths and mechanisms of how the Eco-friendly Packaging variable affects the Purchase Intention variable. This helps identify more specific factors that contribute to the observed results and can provide deeper insight into how consumer behavior is formed.

The data collection method used in this study was data collected using a questionnaire. The data that has been collected is then tested for its feasibility using validity, reliability, and confirmatory factor analysis. The data declared feasible is then analyzed using descriptive statistical and path analyses. In descriptive analysis, the researcher describes the observed variable based on questionnaire data. Meanwhile, verificative analysis intends to test the already estimated hypothesis. This research consists of four hypotheses that will later be tested with the path analysis technique.

The data collected by the researcher is primary data, namely raw data taken by the researcher himself from the primary source for his research, and this data did not previously exist (Juliandi et al., 2014). The technique used in this study is by using a questionnaire. Questionnaires are questions compiled by researchers to find out the opinions or perceptions of research respondents about a variable being studied (Juliandi et al., 2014). The questionnaire in this study uses a scale of 5-Likert that are Strongly Disagree (SD), Disagree (D), Neutral (N), Agree (A), and Strongly Agree (SA).

The population is the totality of all elements in the research area (Juliandi et al., 2014). The population in this study is potential consumers. The population in this study are potential consumers because Brand Value creation begins when companies target potential customers by investing in marketing programs to develop brands, including marketing communications, trade or intermediary support, and product research, development, and design. The AQUA Life product was launched with a new product design; this marketing activity will change the customer's mindset (what customers think and feel) and everything related to the brand (Kotler & Keller, 2016).

The sampling technique used is the purposive sampling method because the potential consumers are comprehensive, and sampling is determined using inclusion and exclusion criteria to ensure that the potential consumers can answer the questions thoughtfully and honestly. The characteristics of the population in this study were consumers who, during the study period, met the inclusion criteria, including domiciled in the city of Bandung, having Minimum high school education, being Accustomed to consuming Bottled Drinking Water, Knowing AQUA Life Products; Not working in Bottled Drinking Water company. The Exclusion Criteria include Not knowing AQUA LIFE products and having a job in a Bottled Drinking Water company.

Samples are representatives of the population (Juliandi et al., 2014). The population used is quite large, and it is not known how many potential consumers for AQUA LIFE product, so in this sampling, the Lemeshow formula will be used (Akdon & Riduwan, 2010) as follows:

$$n = (Z\alpha^2 \times P \times Q) / L^2$$

Information:

- n = Minimum number of samples required
- Z $\alpha$  = Standard value of the distribution according to the value of  $\alpha = 5\% = 1.96$
- P = Outcome prevalence; because the data has not been obtained, 50% is used.
- Q = 1 - P
- L = Accuracy level of 10%

Based on the formula, then:

$$N = ( [(1.96)]^2 \times 0.5 \times 0.5) / ((0.1)^2) = 96.04 \approx 100$$

A confidence level of 95% works well. This means that out of 100, the greater the five errors, the greater the researcher can tolerate to reject H0.

### FINDINGS AND DISCUSSION

Data processing and discussion in this study were obtained from online questionnaire answers given to respondents as the primary data source. The initial stage of screening respondents who met the criteria was conducted by distributing 142 questionnaires and taking sample answers from respondents who did not work in companies that produce bottled drinking water. The following are the results obtained:

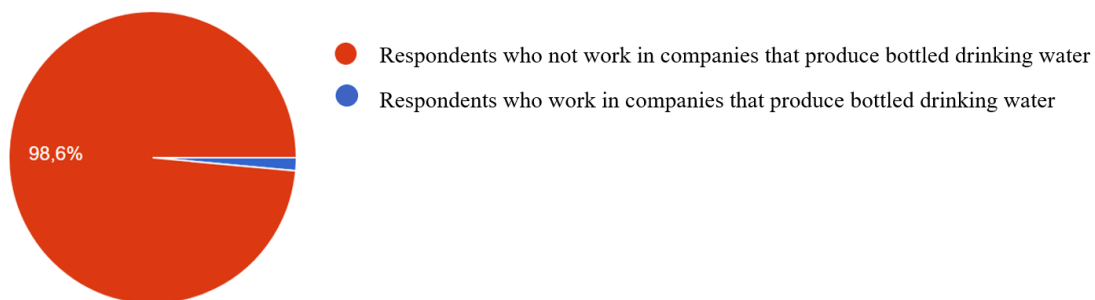

Figure 3. Diagram of respondents who do not work in companies that produce bottled water

Source: Primary data, processed in 2022

Based on the diagram above, of the 142 prospective respondents who answered the questionnaire, 1.4% of respondents worked at a bottled drinking water company. In contrast, 98.6% did not work at a bottled drinking water company. Respondents who met the first criterion of the sample requirements totaled 140 people; the rest (2 people) did not meet the criteria and could not be used as samples.

After getting 140 prospective respondents, a second screening stage was carried out to meet the criteria for respondents, with the respondent required to know AQUA LIFE Products only; the

following results were obtained:

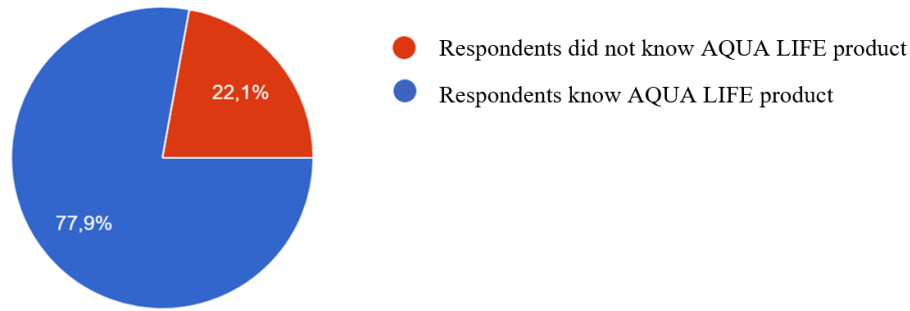

Figure 4. Diagram of Respondents Who Know AQUA LIFE Product  
Source: Primary data, processed in 2022

Based on the diagram above, of the 142 prospective respondents who answered the questionnaire, 77.9% knew about AQUA LIFE products, while the other 22.1% did not know about AQUA LIFE products. Respondents who met the second criterion of the sample requirements were only 109 people; the rest (31 people) were automatically dropped as potential respondents.

Based on the screening process for the first and second samples, the total number of respondents used in this study was 107 respondents.

**Characteristics of Respondents**

The table below is the age distribution of respondents where out of a total of 107 respondents, 44.86% of respondents aged 26-35 years old, ahead of respondents in the age category 18-25 years old with a percentage of 26.17% and ages 36-45 years old with a percentage of 24.30%.

Table 2. Age of Respondents

Age (years old)	Frequency	Percentage
18 - 25	28	26.17%
26 - 35	48	44.86%
36 - 45	26	24.30%
46 - 55	3	2.80%
56 - 65	2	1.87%
<b>Total</b>	<b>107</b>	<b>100.00%</b>

Source: Primary data, processed in 2022

The majority of respondents were dominated by female, with a percentage of 73.83% and 26.17% for men.

Table 3. Gender of Respondents

Gender	Frequency	Percentage
Men	28	26.17%
Women	79	73.83%
<b>Total</b>	<b>107</b>	<b>100.00%</b>

Source: Primary data, processed in 2022

Bachelors dominated the educational level of the respondents with a percentage of 51.40%, ahead of Senior High School with a percentage of 22.43%, and Diploma with a percentage of 14.95%. In comparison, only 11.21% of respondents had a Master's degree.

Table 4. Respondents' Education Level



<b>Educational level</b>	<b>Frequency</b>	<b>Percentage</b>
Senior High School	24	22.43%
Diploma	16	14.95%
Bachelors	55	51.40%
Masters	12	11.21%
<b>Total</b>	<b>107</b>	<b>100.00%</b>

Source: Primary data, processed in 2022

The majority of respondents' occupation as employees is 68.22%, ahead of students and homemakers, with a percentage of 9.35% each.

**Table 5.** Respondent's Occupation

<b>Occupation</b>	<b>Frequency</b>	<b>Percentage</b>
Lecturers	2	1.87%
Teachers	2	1.87%
Housewives	10	9.35%
Employees	73	68.22%
Students	10	9.35%
Government employees	1	0.93%
Healthcare professional	1	0.93%
Entrepreneur	8	7.48%
<b>Total</b>	<b>107</b>	<b>100.00%</b>

Source: Primary data, processed in 2022

### **Validity and Reliability**

#### *Validity and Reliability of Eco-Friendly Packaging*

Table 6 results in validity and reliability testing for the Eco-Friendly Packaging variable question items, where all question items have a value of  $r \geq 0.3$ , concluding that all items are valid. Meanwhile, the reliability value shown by Cronbach's Alpha is 0.8.

**Table 6.** Results of Validity and Reliability Test of Eco-Friendly Packaging Variable

<b>Question</b>	<b>r</b>	<b>Threshold</b>	<b>Remark</b>
EFP11 1. AQUA LIFE product packaging uses materials that can be recycled (different from existing AQUA packaging materials)	0.4	$\geq 0.3$	Valid
EFP12 2. Recycled materials in AQUA Life products are not hazardous materials for consumers	0.3	$\geq 0.3$	Valid
EFP13 3. The size of AQUA LIFE product packaging is by the contents of the product (not too large)	0.3	$\geq 0.3$	Valid
EFP14 4. The number of components in the AQUA LIFE packaging does not cause excessive waste	0.6	$\geq 0.3$	Valid
EFP15 5. AQUA LIFE packaging still has economic value after using the product.	0.4	$\geq 0.3$	Valid
EFP16 6. After the product is used up, the	0.4	$\geq 0.3$	Valid

	AQUA LIFE packaging can be reused with the same function/ reused (Reuse)			
EFP17	7. After the product is used up, the AQUA LIFE packaging can be used/used for other purposes (Reuse).	0.3	$\geq 0.3$	Valid
EFP28	8. The image/packaging design of AQUA LIFE shown reflects the image of an eco-friendly product	0.5	$\geq 0.3$	Valid
EFP29	9. The color of the AQUA LIFE packaging has the image of an eco-friendly product	0.5	$\geq 0.3$	Valid
EFP310	10. The sentences displayed on the AQUA LIFE packaging below have meanings that are easy to understand regarding Eco-Friendly Packaging : "UNTUK INDONESIA LEBIH BERSIH #BIJAKBERPLASTIK"	0.4	$\geq 0.3$	Valid
EFP411	11. The environmental friendliness information displayed on the AQUA Life product below has an easy-to-understand meaning regarding Eco-Friendly Packaging: "TERBUAT DARI 100% PLASTIK DAUR ULANG"	0.5	$\geq 0.3$	Valid
<b>Cronbach'Alpha</b>		<b>0.8</b>	<b><math>\geq 0.6</math></b>	<b>Reliable</b>

Source: Primary data processed by SPSS in 2022

#### *Validity and Reliability of Consumer Perception*

Table 7 is the result of testing the validity and reliability for consumer perception variable question items where all question items have a value of  $r \geq 0.3$ , so it is concluded that all items are valid. Meanwhile, the reliability value shown by Cronbach's Alpha is 0.7.

Table 7. Results of Validity and Reliability Test of Consumer Perception Variable

Question	r	Threshold	Remark
CP112	0.5	$\geq 0.3$	Valid
CP213	0.6	$\geq 0.3$	Valid
CP314	0.5	$\geq 0.3$	Valid
<b>Cronbach's Alpha</b>		<b>0.71</b>	<b><math>\geq 0.6</math></b>
			<b>Reliable</b>

Source: Primary data processed by SPSS in 2022

#### *Validity and Reliability of Purchase Intention*

Table 8 is the result of validity and reliability testing for purchase intention variable question items

where all question items have a value of  $r \geq 0.3$ , so it is concluded that all items are declared valid. Meanwhile, the reliability value shown by Cronbach's Alpha is 0.85.

Table 8. Results of Validity and Reliability Test of Purchase Intention Variable

Question	r	Threshold	Remarks
PI115 15. I intend to buy the AQUA Life product because it is a variant of a well-known brand	0.6	$\geq 0.3$	Valid
PI216 16. I intend to buy AQUA Life product because this product has more attention to environmental conditions	0.7	$\geq 0.3$	Valid
PI317 17. I am interested in trying AQUA Life products because the packaging is eco-friendly/ environmentally beneficial	0.7	$\geq 0.3$	Valid
PI318 18. I want to consume AQUA Life products because of the Eco-Friendly Packaging	0.7	$\geq 0.3$	Valid
PI419 19. I intend to buy AQUA Life product even though it is more expensive than other products	0.6	$\geq 0.3$	Valid
<b>Cronbach's Alpha</b>	<b>0.8</b>	<b><math>\geq 0.6</math></b>	<b>Reliable</b>

Source: Primary data processed by SPSS in 2022

## Descriptive Statistics

### *Descriptive statistics of Eco-friendly Packaging*

Through the answers to the questionnaires collected, researchers can find out the respondents' responses regarding the level of consumer understanding of Eco-Friendly Packaging in AQUA Life products.

Table 9. Recapitulation of Respondents' Responses Regarding Eco-Friendly Packaging on AQUA Life Product

Item	SD (1)		D (2)		N (3)		A (4)		SA (5)		Total Score	Total Score Max	% Avg
	N	%	N	%	N	%	N	%	N	%			
EFP11	1	0.9	0	0.0	6	5.6	63	58.9	37	34.6	456	535	85.2
EFP12	1	0.9	7	6.5	20	18.7	59	55.1	20	18.7	411	535	76.8
EFP13	0	0.0	11	10.3	26	24.3	55	51.4	15	14.0	395	535	73.8
EFP14	0	0.0	3	2.8	30	28.0	57	53.3	17	15.9	409	535	76.4
EFP15	0	0.0	5	4.7	18	16.8	69	64.5	15	14.0	415	535	77.6
EFP16	1	0.9	22	20.6	18	16.8	52	48.6	14	13.1	377	535	70.5
EFP17	0	0.0	3	2.8	14	13.1	75	70.1	15	14.0	423	535	79.1
EFP28	0	0.0	1	0.9	13	12.1	72	67.3	21	19.6	434	535	81.1
EFP29	0	0.0	5	4.7	16	15.0	67	62.6	19	17.8	421	535	78.7
EFP310	0	0.0	1	0.9	1	0.9	76	71.0	29	27.1	454	535	84.9
EFP411	0	0.0	1	0.9	8	7.5	72	67.3	26	24.3	444	535	83.0

<b>Total</b>	4639	5885
<b>Total (%)</b>	78.8	3
<b>Category</b>	Good	

Source: Data primer, (2022)

Based on the total calculation results in Table 9, the total score for Eco-Friendly Packaging for AQUA Life Product is 4639 with a percentage of 78.83% based on the indicators on the continuum line; this score is in the excellent category.

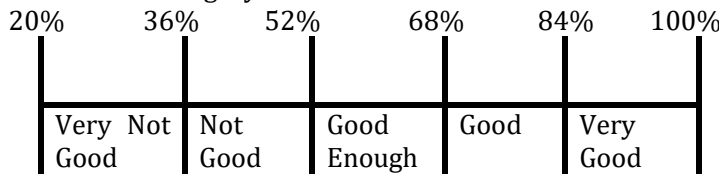

Figure 5. Continuum Line

Referring to the criteria of Magnier, L., & Crié, D in 2015 that packaging that displays a sustainable concept or Eco-Friendly Packaging is communicated through structural cues, graphics, and information cues, which include rational, emotional, and informative claims according to the criteria from Brouwers in 2018, and also the criteria of Krah, Todorovic, & Magnier, L. in 2019 that the combination of graphic cues and information cues into one environmentally friendly label is a good start for communicating packaging sustainability to consumers, which in all consists of 4 sub-variables, seven dimensions and 11 indicators have received good responses from respondents. This means that the respondents assess that the Eco-Friendly Packaging concept shown by AQUA Life Product was good.

*Descriptive Statistics of Consumer Perception*

Through the answers to the questionnaires collected, researchers can find out the respondents' responses regarding the level of Consumer Perception of AQUA Life Products.

Table 10. Recapitulation of Respondents' Responses Regarding Consumer Perception of AQUA Life Product

Item	SD (1)		D (2)		N (3)		A (4)		SA (5)		Total Score	Total Score Max	% Avg
	N	%	N	%	N	%	N	%	N	%			
CP112	0	0.0	0	0.0	17	15.9	54	50.5	36	33.6	447	535	83.5
CP213	0	0.0	7	6.5	36	33.6	52	48.6	12	11.2	390	535	72.9
CP314	0	0.0	0	0.0	35	32.7	62	57.9	10	9.3	403	535	75.3
<b>Total</b>											1240	1605	
<b>Total (%)</b>											77.26		
<b>Category</b>											Good		

Source: Data primer, (2022)

Based on the calculation results in Table 10, the total score for Consumer Perception of the AQUA Life product is 1240, with a percentage of 77.26% based on the indicators on the continuum line; this score is in a suitable category. Referring to the criteria from Shafiquzzaman et al. in 2018 and Arianto in 2020, Consumer Perception is the consumer's interpretation of information, product features, and perceived quality, which consists entirely of 3 sub-variables, three dimensions, and three indicators that have received good responses from respondents. This means that respondents assess AQUA Life to have a good consumer perception.

*Descriptive statistics of Purchase Intention*

Through the answers to the questionnaires that have been collected, the researcher can find out the respondents' responses regarding the level of Purchase Intention on AQUA Life Products.

Table 11. Recapitulation of Respondents' Responses Regarding Purchase Intention of AQUA Life Product

Item	SD (1)		D (2)		N (3)		A (4)		SA (5)		Total Score	Total Score Max	% Avg
	N	%	N	%	N	%	N	%	N	%			
PI115	0	0.0	4	3.7	31	29.0	60	56.1	12	11.2	401	535	74.9
PI216	0	0.0	1	0.9	21	19.6	71	66.4	14	13.1	419	535	78.3
PI317	0	0.0	3	2.8	11	10.3	77	72.0	16	15.0	427	535	79.8
PI318	0	0.0	2	1.9	22	20.6	66	61.7	17	15.9	419	535	78.3
PI419	0	0.0	8	7.5	35	32.7	55	51.4	9	8.4	386	535	72.1
<b>Total</b>											2052	2675	
<b>Total (%)</b>											76.71		
<b>Category</b>											Good		

Source: Data primer, (2022)

Based on the total calculation results in Table 11, the total score for Purchase Intention for AQUA Life Product is 2052 with a percentage of 76.71% based on indicators on the continuum line; this score is in a suitable category. Referring to the criteria from Veybitha et al. in 2021, Yusuf in 2021, and Krisnanda & Nurcaya in 2019, consumers consider Purchase Intention through brands, certain conditions, the desire to try, and prices, which all consist of 4 sub-variables, five dimensions and five indicators has received good responses from respondents. This means that respondents assess that AQUA Life products have a good level of Purchase Intention.

### The Effect of Eco-Friendly Packaging on Consumer Perception

#### *Hypothesis testing*

Hypothesis:

H0: Eco-friendly packaging does not have a positive effect on consumer perception

H1: Eco-friendly packaging has a positive effect on consumer perception

Hypothesis 1 is accepted. Based on the analysis results in Table 12, it can be seen that the effect of Eco-Friendly Packaging on Consumer Perception obtained a Significance value of 0.000 with a beta coefficient of 0.58. This concludes that Regression 1, namely variable X, significantly affects Z. A significance value of  $0.000 < 0.05$  indicates that H0 is rejected and H1 is accepted. This result means that Eco-Friendly Packaging positively and significantly affects Consumer Perception at AQUA Life in Bandung. These results indicate that the values contained in Eco-Friendly Packaging in AQUA Life products are well perceived and impact Consumer Perception.

#### *Goodness of Fit*

Table 12. R-Square: The Direct Effect of Eco-Friendly Packaging on Consumer Perception

R	R Square	Adjusted R Square
0.58	0.34	0.33

Source: Data primer, Processed by SPSS (2022)

Based on Table 12, the magnitude of the effect of the independent variables on the dependent variable is shown by the total determination value (R Square) of 0.34, which means that the

contribution of the effect of Eco-Friendly Packaging on Consumer Perception is 34%. In comparison, the remaining 66% is a contribution from other variables that are not included in the research. Other variables that can potentially affect Consumer Perception include product quality, company reputation, and cultural factors such as values, norms, and societal beliefs that affect consumer perceptions. So, Eco-Friendly Packaging strengthens the Consumer Perception. Meanwhile, the value of E1 can be found using the formula  $E1 = \sqrt{(1-0.34)} = 0.812$ .

Table 13. Partial Test (t-test) Direct Effect of Eco-Friendly Packaging on Consumer Perception

Variable	Unstandardized Coefficients		Standardized Coefficients		
	B	Std. Error	Beta	t	Sig.
(Constant)	2.37	1.27	0	1.87	0.064
Eco-Friendly Packaging	0.23	0.03	0.58	7.3	0

Source: Data primer, Processed by SPSS (2022)

In Table 13, the calculated t value for the Eco-Friendly Packaging variable on Consumer Perception is 7.3, and the t table value with a sample size of 107 and an alpha of 0.05 is 0.67681. The calculated value of the t variable is greater than the t table, so the Eco-Friendly Packaging variable has a significant effect on the Consumer Perception variable.

### The Effect of Consumer Perception on Purchase Intention

#### Hypothesis testing

Hypothesis:

H0: Consumer perception does not have a positive effect on purchase intention

H2: Consumer perception has a positive effect on purchase intention

Hypothesis 2 is accepted. Based on the results of the analysis in Table 4.26, it can be seen that the effect of Consumer Perception on Purchase Intention obtained a Significance value of 0.000 with a beta coefficient of 0.47. A significance value of  $0.000 < 0.05$  indicates that H0 is rejected and H2 is accepted. This result means that Consumer Perception positively and significantly affects Purchase Intention at AQUA Life in Bandung.

Table 14. Partial Test (t-test) Direct Effect of Consumer Perception on Purchase Intention

Variable	Unstandardized Coefficients		Standardized Coefficients		
	B	Std. Error	Beta	t	Sig.
Consumer Perception	0.75	0.15	0.47	4.94	0

Source: Data primer, Processed by SPSS (2022)

In Table 14, the calculated t value for the Consumer Perception variable on Purchase Intention is 4.94, and the t table value with a sample size of 107 and an alpha of 0.05 is 0.67681. The calculated value of the t variable is greater than the t table, so the Consumer Perception variable has a significant effect on the Purchase Intention variable. It can be concluded that Consumer Perception strengthens Purchase Intention.

### The Direct Effect of Eco-Friendly Packaging on Purchase Intention

#### Hypothesis testing

Hypothesis:

H0: Eco-friendly packaging has no direct effect on Purchase intention  
 H3: Eco-Friendly Packaging has a direct effect on Purchase intention

Hypothesis 3 is accepted; based on the analysis results in Table 15, it can be seen that the effect of Eco-Friendly Packaging on Purchase Intention directly obtained a Significance value of 0.023 with a beta coefficient of 0.22. This concludes that Regression 2, namely variable X, significantly affects Y. A significance value of  $0.000 < 0.05$  indicates that H0 is rejected and H3 is accepted. This result means Eco-Friendly Packaging positively and significantly affects Purchase Intention at AQUA Life products in Bandung.

Based on the tests in Tables 13 and 15, it can be seen that Consumer Perception has a significantly more significant positive effect than Eco-Friendly Packaging. This is indicated by the influence (beta) of Consumer Perception of 0.47, while Eco-Friendly Packaging is 0.22. These results indicate that Consumer Perception of AQUA Life products has a more significant impact on Purchase Intention.

*Goodness of Fit*

Table 15. R-Square Direct Effect of Eco-Friendly Packaging on Purchase Intention

R	R Square	Adjusted R Square
<b>0.62</b>	0.38	0.37

Source: Data primer, Processed by SPSS (2022)

Based on Table 15, the magnitude of the effect of the independent variables on the dependent variable is shown by the total determination value (R Square) of 0.38, which means that the variance of the Purchase Intention data can be explained by the Eco-Friendly Packaging and Consumer Perception variables of 38%. In comparison, the remaining 62% is contributed by other variables not included in the study. Other variables that can affect Purchase Intention include promotions, discounts, or other special offers that can affect Purchase Intention by creating additional benefits for consumers and the availability and ease of access to obtain products. So, to-friendly Packaging strengthens the Purchase Intention.

Meanwhile, the value of E2 can be found using the formula  $E2 = \sqrt{(1-0.38)} = 0.787$ .

Table 16. Partial Test (t-test) Direct Effect of Eco-Friendly Packaging on Purchase Intention

Variable	Unstandardized Coefficients		Standardized Coefficients		
	B	Std. Error	Beta	t	Sig.
Eco-Friendly Packaging	0.14	0.06	0.22	2.3	0.023

Source: Data primer, Processed by SPSS (2022)

In Table 16, the calculated t-test value for the Eco-Friendly Packaging variable for Purchase Intention is 2.3, and the t-table value with a sample size of 107 and an alpha of 0.05 is 0.67681. The calculated value of the t variable is greater than the t table, so the Eco-Friendly Packaging variable has a significant effect on the Purchase Intention variable.

**The Indirect Effect of Eco-Friendly Packaging on Purchase Intention Mediated by Consumer Perception**

*Hypothesis testing*

Hypothesis:

H0: Eco-friendly packaging does not affect Purchase intention indirectly through Consumer perception

H4: Eco-friendly packaging has an indirect effect on Purchase intention through Consumer perception

Based on the test in the table, it can be seen that the effect of Eco-Friendly Packaging on Purchase Intention indirectly obtained a Significance value of 0.022 with a beta coefficient value of 0.273. A significance value of  $0.000 < 0.05$  indicates that H0 is rejected and H4 is accepted. This result means that Eco-Friendly Packaging at AQUA Life has a positive and significant indirect effect on Purchase Intention through Consumer Perception.

Based on the tests in Tables 16 and 17, it can be seen that the indirect effect of Eco-Friendly Packaging on Purchase Intention is 0.273, where this effect is greater than the direct effect of Eco-Friendly Packaging, which only has an effect of 0.22. This means that consumer perception as an intervening variable has a significant impact on mediating eco-friendly packaging on purchase intention for AQUA Life products. The findings in this study are supported by Kotler Keller's (2016) theory that product design can change consumer perceptions. Consumer behavior will arise from these perceptions in response to objects by showing a desire to buy.

The following is the Final Path Analysis Model to illustrate the magnitude of the effect of each variable.

Table 17. Significance of the indirect effect of Eco-Friendly Packaging on Purchase Intention mediated by Consumer Perception

Variable	Standardized Coefficients		
	Beta	t	Sig.
Eco-Friendly Packaging	0.273	3.09	0.002

Source: Data primer, Processed by SPSS (2022)

In Table 17, the t-test value for the Eco-Friendly Packaging variable on Purchase Intention mediated by Consumer Perception is 3.09, and the t-table value with a sample size of 107 and an alpha of 0.05 is 0.67681. The calculated value of the t variable is greater than the t table, so the Eco-Friendly Packaging variable has a significant effect on the Purchase Intention variable indirectly mediated by Consumer Perception. So, ito-friendly Packaging strengthens the relationship between Consumer Perception and Purchase Intention. This means Consumer Perception is needed to support Purchase Intention on AQUA Life products.

Figure 6. Final Path Analysis Mod

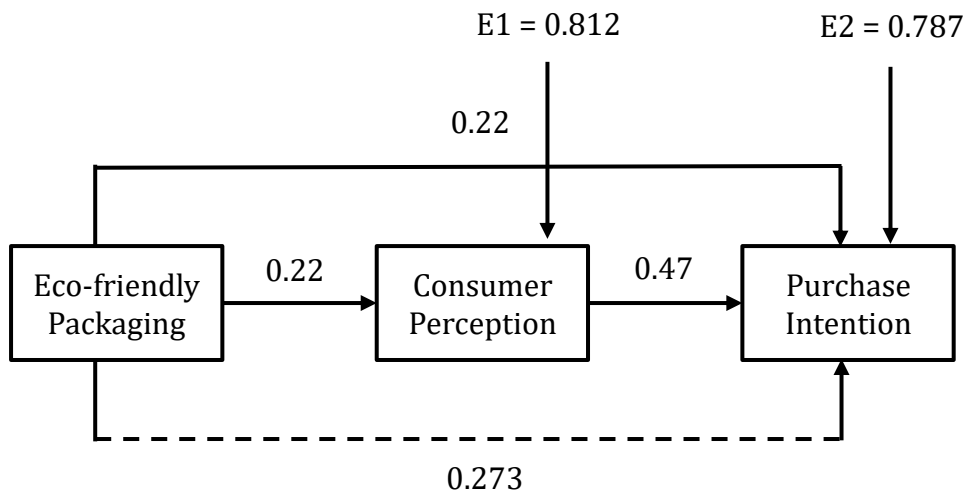

el



---

Source: Created by Researcher based on analysis results

## CONCLUSIONS

Eco-friendly packaging is shown by AQUA Life Product through structural cues, graphic cues, and claims, including emotional claims about the environment and rational informative claims related to packaging that respondents easily understand. AQUA Life product has a good level of Consumer Perception for respondents. The dimension of interpretation gets the highest average score, and the dimension of product feature gets the lowest average score. AQUA Life has a good level of Purchase Intention for respondents. The dimension of interest to try gets the highest average score, and the dimension of the price (willingness to pay a higher price) gets the lowest average score. Eco-friendly packaging positively and significantly affects Consumer Perception of AQUA Life products in Bandung. Consumer Perception positively and significantly affects Purchase Intention on AQUA Life products in Bandung. Eco-friendly packaging has a direct effect on Purchase Intention at AQUA Life. Eco-friendly packaging at AQUA Life indirectly affects Purchase Intentions through Consumer perception, with a value greater than the direct effect. This means that Consumer Perception as an intervening variable significantly influences Eco-Friendly Packaging on Purchase Intention for AQUA Life products.

Suggestions for the company to improve features that make this product different from general bottled water products so that consumers perceive that consuming products with Eco-Friendly Packaging is better than other products. Companies can highlight the concept of eco-friendly products by providing consumers with the idea of using empty bottles (Reuse) or sorting instructions for disposing of bottle waste. Companies can reconsider the selling price of the product or increase the product's value even higher so that consumers can also increase their willingness to buy the product even at a higher price. Suggestions for future researchers to conduct similar research with a broader population include using other variables and conducting interviews to get respondents' reasons regarding the answers chosen to perfect the current research.

## LIMITATION & FURTHER RESEARCH

Scientific procedures have carried out this research. However, it still has limitations, such as the number of respondents, the variables used, and no interviews to get the reasons from respondents related to the answers chosen to perfect the current research. Other variables that can potentially affect Consumer Perception include product quality, company reputation, and cultural factors such as values, norms, and societal beliefs that can influence consumer perceptions. Other variables that have the potential to influence Purchase Intention include promotions, discounts, or other special offers that can influence Purchase Intention by creating additional incentives or benefits for consumers as well as the availability and ease of access to obtain products.

## REFERENCES

- Akron, R. (2010). *Rumus dan Data Dalam Analisis Statistika*, Cetakan Kedua. Alfabeta. Bandung.
- Arianto, T. R. P. B. (2020). Analisis Faktor-faktor yang Mempengaruhi Persepsi Konsumen Terhadap Mobil Merk Toyota (Studi pada Mahasiswa STIE Malangkececwara) (Doctoral dissertation, STIE Malangkececwara). <https://repository.stie-mce.ac.id/id/eprint/1009>
- AQUA Life. Inovasi Botol Pertama di Indonesia. available at <https://aqua.co.id/brand/aqua-100-recycled>
- AQUA Grup. AQUA Grup Menerapkan Nilai-Nilai Danone yang Menggambarkan Visi dan Etika Bisnis yang Unik. available at <https://aqua.co.id/aqua-group>
- Aqua, (10 Juni 2020), Danone-Aqua Kembali Raih Penghargaan Kinerja Pengurangan Sampah oleh Produsen Dari KLHK, available at <https://aqua.co.id/danone-aqua-kembali-raih-penghargaan-kinerja-pengurangan-sampah-oleh-produsen-dari-klhk>
- Badan Pusat Statistik. (2021). STATISTIK LINGKUNGAN HIDUP INDONESIA 2021. Katalog BPS 3305001.
- Brouwers, T. (2018). How Communicating Sustainable Packaging Impacts the Consumer's Purchase Intention (Doctoral dissertation).
- Cameron, P. (2015). *Ultimate Marketing Tools*. Australian ebook Publisher.
- Guerra, R. M. A. M. (2019). The Impact of Sustainable Packaging on the Purchase Intent of
-

- Consumers (Doctoral dissertation). Universidade Católica Portuguesa.
- Juliandi, Irfan, Manurung. (2014). *Metodologi Penelitian Bisnis, Konsep dan Aplikasi*. Medan: UMSU Press.
- Julianti, Sri. (2014). *The Art of Packaging*. Jakarta: Kompas Gramedia
- Krah, S., Todorovic, T., & Magnier, L. (2019). Designing for Packaging Sustainability. The Effects of Appearance and a Better Eco-Label on Consumers' Evaluations and Choice. *In Proceedings of the Design Society: International Conference on Engineering Design* (Vol. 1, No. 1, pp. 3251-3260). Cambridge University Press. <https://doi.org/10.1017/dsi.2019.332>
- Krisnanda, A. D. I., & Nurcaya, I. N. (2019). Pengaruh Kesadaran Lingkungan Terhadap Persepsi Konsumen Dan Niatbeli Produk Lampu Led Philips Dikota Denpasar. *E-Jurnal Manajemen*, 8(2), 8075-8103. <https://doi.org/10.24843/EJMUNUD.2019.v8.i2.p19>
- Kotler, K. (2016). *Marketing Management*. England: Pearson Education Limited.
- Magnier, L., & Crié, D. (2015). Communicating Packaging Eco-Friendliness. *International Journal of Retail & Distribution Management*, 43(4/5), 350. <https://doi.org/10.1108/IJRDM-04-2014-0048>
- Picaully, M. R. (2018). Pengaruh Kepercayaan Pelanggan Terhadap Niat Pembelian Gadget Di Shopee Indonesia. *Jurnal Manajemen Maranatha*, 18(1), 31-40. <https://doi.org/10.28932/jmm.v18i1.1094>
- Rani, M. G. (2017). Eco-Friendly Packaging and Consumer Behaviour. *Catalyst*, 2(2), 58-68.
- Santoso, I., & Fitriani, R. (2016). Green Packaging, Green Product, Green Advertising, Persepsi, dan Minat Beli Konsumen. *Jurnal Ilmu Keluarga & Konsumen*, 9(2), 147-158. <https://doi.org/10.24156/jikk.2016.9.2.147>
- Sarwono, J. (2011). Mengenal Path Analysis: Sejarah, Pengertian dan Aplikasi. *Jurnal Ilmiah Manajemen Bisnis*, 11(2), 285-296.
- Shafiquzzaman, M., Haider, H., AlSaleem, S. S., Ghumman, A. R., & Sadiq, R. (2018). Development of Consumer Perception Index for assessing greywater reuse potential in arid environments. *Water SA*, 44(4), 771-781. <https://doi.org/10.4314/wsa.v44i4.25>
- Sekarlaranti, A., & Junaedi, S. (2013). Persepsi Konsumen Terhadap Warna, Tipografi, Bentuk Grafis dan Gambar pada Kemasan Produk dengan Pendekatan Multidimensional Scaling. *Jurnal Manajemen Teori dan Terapan*, 6(1).
- Setiadi, N. J., & SE, M. (2019). *Perilaku Konsumen: Perspektif Kontemporer pada Motif, Tujuan, dan Keinginan Konsumen*. Edisi Ketiga (Vol. 3). Prenada Media.
- Sugiyono, (2007), *Statistika untuk Penelitian*, Bandung: CV Alfabeta.
- Van den Elzen, J. (2016). Consumers' Perception Regarding Sustainable Packaging (Doctoral dissertation, Thesis for the Marketing and Consumer Behaviour Group. Wageningen, Netherlands: Wageningen University). <https://doi.org/10.32535/jicp.v4i1.1162>
- Yusuf, D. M. (2021). Effect of Attitude Mediating Subjective Norm, Perceived Behaviour Control, and Perceived Ease of Use on Online Purchase Intention Fashion Product Category. *European Journal of Business and Management Research*, 6(6), 266-270. <https://doi.org/10.24018/ejbmr.2021.6.6.1135>