



Effect of Planning and Budget Realization with Covid-19 As A Moderator Variable toward Budget Absorption in Resort Police Station Bangka Tengah

Harry Pranajaya^{1*}, Lela Nurlaela Wati², Ira Geraldina³

^{1,3} Universitas Terbuka, Indonesia

² Universitas Teknologi Muhammadiyah Jakarta, Indonesia

Received : February 13, 2024

Revised : April 19, 2024

Accepted : April 29, 2024

Online : April 30, 2024

Abstract

In response to the Covid-19 pandemic, the government prioritized allocating a significant portion of its resources toward preventing the spread of Covid-19. Undoubtedly, this will inevitably affect the meticulously devised programs aimed at achieving budgetary recuperation. This study aims to determine the extent to which Covid-19 affects the budget absorption of the Resort Police Station Work Unit in Bangka Tengah. This study utilizes a quantitative methodology, utilizing moderating regression analysis (MRA) for data analysis. The financial statements cover a period of 72 months, spanning from 2017 to 2022. The study discovered that both the planning and implementation of activities, as well as the regulation of the Covid-19 pandemic's impact on planning and implementation, had a noteworthy influence on the utilization of funds at the Resort Police Station Bangka Tengah. This study demonstrates that the planning process at the Bangka Tengah Police is capable of adjusting to the current requirements, resulting in improved budget use. The Bangka Tengah Police can improve budget absorption by implementing monthly budget realization. No prior research has been conducted on budget absorption at the Police Station during the Covid-19 pandemic, which had a widespread impact on all aspects of life.

Keywords: *Planning; Realization; Covid-19 Pandemic; Budget; Budget Absorption*

INTRODUCTION

A state agency's budget plays a critical role in determining its survival. Spending in the fiscal sector not only funds governmental operations but also acts as a tool for policymaking. Government spending also stimulates the overall economy. This government expenditure is described in the Indonesian Budget/APBN (Asrudi, 2020).

The amount of money spent is influenced by both budget planning and budget realization. Suhartono (2011) asserts that "the gap between planning and realization is a problem that is often encountered in realizing the budget; as a result, the approved budget cannot always be used and is not absorbed in the program that has been set". The first factor that affects how quickly the budget is realized is issues that arise within work units, such as the slow appointment of financial management professionals, the propensity to put off decisions, and the absence of reward and punishment mechanisms in work unit budget management (Miliasih, 2012). The purchase of goods and services follows. Those in charge of purchasing goods and services use caution in their decisions. Maximum budget absorption does not keep up with the yearly rise in the share of central government spending. Because of expenditure by Ministries/Institutions like the Bangka Tengah Police work unit, spending patterns with poor absorption characteristics in the first semester have emerged recently even in the last quarter of the current fiscal year's fourth semester. The first semester had the same expenditure trend with minimal absorption characteristics at the levels of the Bangka Tengah Police, Regional Police, and National Police (Syahwildan & Damayanti, 2022)

Furthermore, delays in the absorption of the budget can result in a decrease in the present value of the budget, so that the impact on economic growth becomes smaller than expected because the output tends to be lower. Public service as the main aspect of government performance is also

Copyright Holder:

© Pranajaya et al. (2024)

Corresponding author's email: harrypranajaya94@gmail.com

This Article is Licensed Under:



measured by its present value to the community (Graham & Harvey, 2002).

The global expansion of the Covid-19 pandemic coincided with an economic crisis. All countries across the globe, including Indonesia, are susceptible to this phenomenon. The emergence of Covid-19 rapidly triggered a multifaceted crisis encompassing health, economic, and geopolitical dimensions, leading to a near-complete halt in the tourism, aviation, and travel industries (Ilhamsyah et al., 2023; Ridzuan & Rahman, 2021). This has a significant influence on economic activity and the allocation of government funds, thus affecting the design and implementation of the government budget in Indonesia.

Budget absorption effectiveness in the regions in handling Covid-19 after budget reallocation policy and program adjustments. By designating the Regional Government Budget (APBD) for sustainable development, this research attempts to address a variety of field difficulties and establish local government solutions to the Covid-19 pandemic. The Covid-19 pandemic has been found to reduce local own-source revenue (LOR), general allocation fund (GAF) indicators, funding, and local governance spending. However, the most notable impacts are observed in GAF and local governance expenditure. The sluggish economic growth in Indonesia during the Covid-19 pandemic in 2020 can be attributed to the impact on the LOR component, which subsequently led to a decrease in local government spending (Wati et al., 2022).

The financial data from the Technical Management Support for Maintaining Security and Public Order at the Bangka Tengah Police, which was redirected to address Covid-19, resulted in changes in planning and implementation compared with the pre-COVID period. This was due to a budget reallocation carried out by the police to assist the community in combating the Covid-19 pandemic. The reallocation of funds for official travel has become more significant because of the heightened police operations associated with Covid-19. Meeting expenses have been altered due to the shift to online platforms like Zoom. Honorariums for activities previously conducted in person have transitioned to online formats, including ceremonial events. Court trials are now being conducted online, and social assistance and health care services have been extended to the community. No prior research has investigated the impact of the Covid-19 pandemic on budget planning, implementation, and use by the Bangka Tengah Police or other police agencies at the national level during the Covid-19 period. The Bangka Tengah Police have observed gaps and discrepancies between the realization and absorption rates compared with the previous year. The occurrence of Covid-19, both during and after the pandemic, has catalyzed researchers to undertake this study. This research intends to assess the impact of budget planning and implementation on the budget absorption of the Bangka Tengah Police Work Unit, both under normal circumstances and during the Covid-19 pandemic.

LITERATURE REVIEW

Stewardship Theory

Stewardship theory implicitly demonstrates how accounting constructs leadership patterns between top management and lower levels of management within an organization. Sudaryo et al. (2021) suggested that stewardship theory applies to accounting for public sector organizations, including government and nonprofit organizations. This notion can be applied to the public sector as the steward performs the instructions of the principal. This implies that the government will fulfill its responsibilities in alignment with the desires and welfare of the populace. This theory posits a robust correlation between happiness and organizational success to foster public trust in government organizations by using the budget provided by the government through financial reports.

The aforementioned theory is directly relevant to the performance of police organizations, specifically the Bangka Tengah POLRES, in effectively managing an organization that aligns with the

primary responsibilities outlined in POLRI Law No. 2 of 2022, specifically Article 13. These responsibilities include providing protection, guidance, and service to the community. It is crucial for the POLRI organization to efficiently utilize its budget to avoid negative consequences such as diminished service quality and delayed benefits for the community.

Budget

A budget is a strategic tool used to plan and manage the financial resources of a government system to achieve efficiency and effectiveness (Widanaputra & Mimba, 2014). According to Astrajingga (2013), a budget is a strategy that organizes all corporate activities for a predetermined period in the future in a logical manner using numbers indicated in money units. Since the plans made are expressed in monetary terms, the budget occasionally refers to the planning of finances. The budget relies heavily on both monetary units and activity units. All actions will be measured in monetary terms, allowing for the measurement of the efficiency and efficacy of the activities performed. A budget is a written management commitment that details what the management anticipates in terms of future revenues, spending, and different financial activities. Budgeting allows management.

Planning

A crucial step in the organizational management process is budget planning. Budget planning is the methodical arrangement of figures and money stated in monetary units that covers all business operations for a future time (period). Because they are expressed in terms of monetary units, budgets are usually referred to as financial plans. Since all activities will be defined in monetary terms, activity units and monetary units are crucial to budget planning, allowing for the measurement of the efficiency and effectiveness of the activities to be carried out. Creating a budget, also known as a budget plan, is a written management commitment that relates to management expectations for income, expenses, and different financial activities within a specific time frame. Research conducted by Ferdinan et al. (2020) states that budget planning has a significant positive effect on budget absorption, whereas budget implementation does not affect budget absorption.

Realization

Budget absorption is impacted by several factors, including budget realization. The following factors in the actualization of the budget have an impact on its good or bad absorption: a) Internal work unit problems might include: delays in issuing the decision letter to the finance management staff, frequent transfers of financial management officials, implementation of activities that do not follow the schedule in the Budget Implementation Registration Form (DIPA), the continued presence of an asterisk (block) on the budget ceiling, and the delay in the appointment of financial management officials. Employee resistance to serving as Commitment Making Officers (PPK) for the Procurement of Goods and Services was not a new problem. Payment Mechanism (budget distribution) with 2 (two) payment modalities, namely the mechanism through Supply Money (UP) and the system for direct payments to third parties (LS or Non-Cash), which has now been implemented.

Absorbing

Budget absorption, as defined by Susanto and Rahayu (2010), is the outcome of a budget's accomplishment or last voyage after planning and budget realization. The effectiveness and efficiency of the budget's absorption are taken into consideration, not just if it is at or near its maximum level. It is well known that the cycle of central and regional government budget absorption in 2017 and prior years has not altered; as a result, budget absorption is consistently

below the goal. Because of the practice of using the budget more quickly near the end of the year, it is unquestionably true that spending money is not efficient or ideal. Of course, it is unreasonable to anticipate that government expenditure will serve as a vehicle for economic stimulation if most it consumes the annual budget. Despite being a budgetary tool, the APBN/APBD should be able to boost economic activity. Budget absorption, on the other hand, goes beyond simply spending money; it also refers to how to use that money as efficiently as possible to obtain the desired results and meet set objectives.

Pandemic of Covid-19

Regarding the implications of the pandemic, some preparations are concentrated on the significant Covid-19 preventive budget. This will surely impact the plans to restructure the budget for the Bangka Tengah Police Station unit. Researchers looked at the Covid-19 moderation variable as a moderator variable on the absorption of the Bangka Tengah Police work unit budget to see if the Covid-19 pandemic moderated the effects of budget planning and realization on budget absorption as well as if it moderated the influence of the Covid-19 pandemic on budget absorption.

Theoretical framework and hypothesis

The National Planning development system is a coordinated method for developing yearly, medium-term, and long-term plans for development that is used by parts of federal and local government administration, which among other things aims to guarantee integration, synchronization, and synergy across regions, places, times, and the activities of the Central and Regional governments, and facilitate collaboration among development players. Budget planning is crucial and plays a part in a nation's sustainability, according to [Idrus et al. \(2021\)](#). In addition to serving as a means of funding governmental activities, expenditure serves as a helpful instrument in the field of finance. Likewise, so it seems. Due to inadequate planning, the maximum budget absorption does not keep pace with the yearly growth in the percentage of central government expenditure. According to [Syahwildan and Damayanti \(2022\)](#), this influences the budget's ineffectiveness as a catalyst for improving police performance. If the delay is due to service-related activities, it will also hurt how quickly the community will get and enjoy its advantages, which will result in subpar service. [Hung and Luo \(2016\)](#) demonstrated that insufficient preparation leads to subpar budget absorption. effects of financial information systems interruption on next planning. Therefore, the following hypothesis might be advanced considering the theoretical underpinnings and the above empirical observations (*See Figure 1*).

H1: Budget Planning has a positive effect on Budget Absorption

Budget Realization is action or effort taken to perform all previously developed and decided plans and policies ([BPKP, 2011](#)). The Budget is realized once the Budget Implementation List (DIPA) document has been authorized by the Minister of Finance via approval of the DPR. According to a study ([Ratag et al., 2021](#)), failure to submit an invoice to a provider or an incomplete billing document to a provider can also result in late payments to providers of goods and services. [Rakhman \(2019\)](#) determined that the degree of budget absorption is influenced by leadership variables such as mayors' terms, tenure, and age, as well as the amount of capital expenditures. A greater allocation of funds toward capital expenditures decreases the extent to which the budget is implemented. Meanwhile, according to [Kuswoyo \(2012\)](#), the slow fulfillment of the budget causes the costs piling up after the fiscal year. Likewise, [Nuraeni and Suryana \(2020\)](#) suggests that the budget cycle, which consists of budget preparation/planning, budget implementation/realization, budget monitoring, and budget reporting and accountability, becomes one correlated unit, one of

which is realization, which affects budget absorption in general. On the basis of the theoretical basis and empirical findings above, the following hypotheses can be proposed:

H2: Budget Realization has a positive effect on Budget Absorption

The viability of a nation is largely dependent on effective budget planning. In addition to serving as a means of supporting government activities, expenditure is utilized as a tool to broaden the fiscal sector (Syahwildan & Damayanti, 2022). Budget realization, according to Yanuriza et al. (2019), refers to all actions taken to perform the plans and policies that have been made and decided upon (BPKP, 2011). Budget realization begins with the Minister of Finance's signature on the Budget Implementation List document (DIPA), which is followed by DPR approval. Research (Ratag et al., 2021) claims that vendors of products or services might also induce delays in payments by failing to submit a bill or because the provider received incomplete proof of billing documentation. Meanwhile, according to Kuswoyo (2012), expenditure constraints at the end of the fiscal year are brought on by the budget's sluggish fulfillment. Similarly, Kania et al. (2021), during the Covid-19 epidemic, several initiatives, including those that support healthy living and prosperity, budget absorption, family resilience, family economic life, and the role of women in development, saw significant adjustments. This demonstrates how the Covid-19 epidemic negatively impacted the execution of authorized budget absorption and planning. Jaweng et al. (2020) reveals that this research also develops policy suggestions that might assist local governments in adjusting to IMR to revive the national economy. The policy recommendations in this research are intended to support SDGs within the framework of sustainable development, without having to conflict with the strategic focus (budget reallocation and priority targets in the adjustment program), which will continue to focus on the following year. The Covid-19 epidemic undoubtedly impacts budget absorption, which is not what was anticipated, according to theory and prior studies. The following hypothesis may be proposed based on the theoretical underpinnings and the aforementioned empirical results.

H3: The Covid-19 pandemic has had a negative impact on Budget Absorption

The gap between planning and realization is a problem that is often faced in realizing the budget. Because of this, the approved money cannot always be used and is not incorporated into the chosen program. Similar to this, according to Kania et al. (2021), certain activity programs, such as those that support wholesome and prosperous socialization, the contribution of women to development, budget absorption, family resilience, and family economic life, have seen significant changes because of the Covid-19 epidemic. This demonstrates how the Covid-19 epidemic has negatively impacted both the execution of authorized budget absorption and planning. The following hypothesis can be advanced considering the foregoing theoretical underpinnings and empirical findings:

H4: The Covid-19 pandemic weakens the influence of Budget Planning on Budget Absorption

The reason for the increase in spending toward the conclusion of the fiscal year is the budget's tardy realization. The budget cycle is also found to consist of budget preparation/planning, budget implementation/realization, budget monitoring, as well as budget reporting and accountability, into one interconnected unit, one of which is that realization will influence budget absorption generally (Nuraeni & Suryana, 2020). Jaweng et al. (2020) reveals that this research also develops policy suggestions that might assist local governments in adjusting to IMR to revive the

national economy. The policy proposals in this study are designed to assist SDGs within the framework of sustainable development during the Covid-19 pandemic without clashing with the focal strategy (budget reallocation and Priority goals in program modifications), which will continue to be the course for the following year. The following hypothesis can be advanced considering the foregoing theoretical underpinnings and empirical findings:

H5: The Covid-19 pandemic weakens the influence of Budget Realization on Budget Absorption

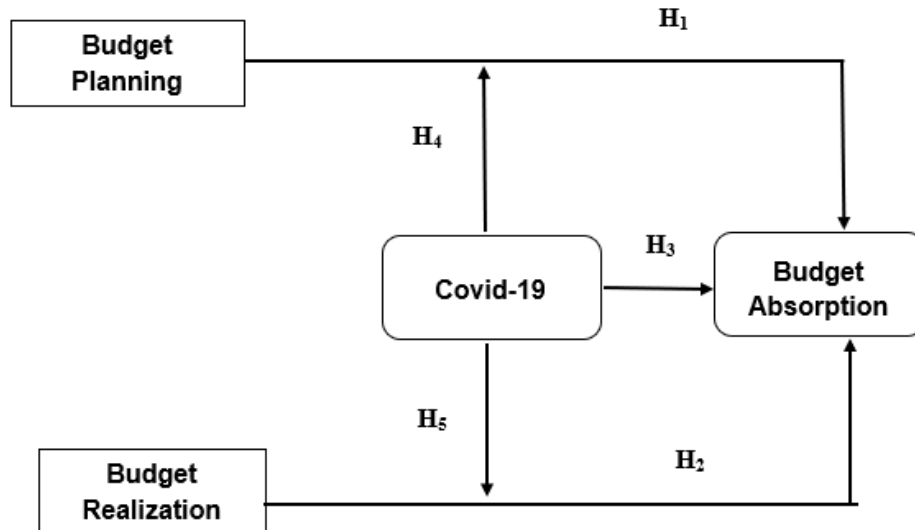

Figure 1. Conceptual Framework

RESEARCH METHOD

This type of research is quantitative analysis in nature with the design of budget planning and budget realization by the allocation of funds contained in the Bangka Tengah Police Work Unit DIPA. The budget can be absorbed optimally or not, optimally absorbed or not, effective and efficient or not, beneficial or not, all of which will have a direct impact on the absorption of the budget itself. The population used in this study is the financial statements of the Bangka Tengah Police work unit. The financial statements are five years in 72 months from 2017 to 2022. The number of samples is 72 months, with details from January 2017 to February 2020, the period before the COVID-19 pandemic, and from March 2020 (the beginning of the Covid-19 pandemic) until December 2022 (Government revoked PPKM)

Table 1. Research Variables and Measurement Methods

| Variable | Indicator | Measurement | Source |
|-------------------------|---|--|---|
| Budget Planning (PA) | a method for selecting the best future courses of action while considering the available resources and going through a series of options. | Ratio Nominal In the rupiah (Rp) | Scale: Republic Indonesia Law No. 25 (2004) |
| Budget Realization (RA) | the amount of budget realized to produce Program Output achievements | Ratio Nominal In the rupiah (Rp) | Scale: Minister of Finance Regulation No.22/PMK.02/2021 Concerning Measurement |

| Variable | Indicator | Measurement | Source |
|-------------------------|---|--------------------------|--|
| Budget Absorption (PYA) | Compare budget realization and ceiling in the last DIPA multiplied by 100%. This study used panel data regression analysis | Ratio Nominal percentage | Scale: in Minister of Finance Regulation No.22/PMK.02/2021 Concerning the Measurement and Evaluation of Budget Performance on the Implementation of Work Plans and Budgets of State Ministries/Institutions, Fauzie (2022) |

This study used multiple linear regression analysis to determine the relationship between the independent variables (PA and RA) moderated by COVID on the dependent variable PYA. The general formula for multiple linear regression:

$$PYA = \alpha + \beta_1PA + \beta_2RA + \beta_3COV + \beta_4PA * COV + \beta_5 RA * COV + \epsilon.....(1)$$

FINDINGS AND DISCUSSION

Multiple Regretion Liner

Partially testing the influence of the variables Planning, realization, covid, planning moderation, and realization moderation on the absorption variables is described as follows:

Table 2. Regression Analysis

| Model | B | T-Test | Sig |
|-----------------------------|-----------|---------|-------|
| (Constant) | 103.972 | 79.423 | 0.000 |
| Budget Planning | -4.475E-8 | -43.570 | 0.000 |
| Budget Realization | 4.323E-8 | 43.829 | 0.000 |
| Covid-19 Pandemic | -5.013 | -3.509 | 0.001 |
| Budget Planning Moderate | 2,251E-8 | 8.499 | 0.000 |
| Budget Realization Moderate | -2.071E-8 | -7.750 | 0.000 |

Source: Processed using SPSS

Based on Table 2, the multiple regression equation model is obtained as follows:

$$PYA = 103.972 - 4.475PA + 4.323RA + 5.031COV + 2.251PA*COV - 2.071RA*COV$$

Budget Planning has negative coefficient value of 4.475. This suggests that budget absorption and planning have a connection that runs counter to one another. Accordingly, if the other independent variables from the regression model remain constant, the beta variable (PYA) will drop by 4.475 for every unit increase in planning. Work unit budget planning that is still poor tends to slow down the absorption of work unit budgets. On the other hand, if the planning of the work unit budget has been done Well, then there is a tendency to improve budget absorption in the work unit.

Budget Realization coefficient value is 4.323 and is marked positive, demonstrating a clear correlation between Realization and budget absorption. This suggests that if the other independent variables from the regression model remain constant, the Beta (PYA) variable will grow by 4.323 for every increase in Realization of one unit. The realization that runs smoothly will result in maximum budget absorption.

Covid-19 Pandemic has negative coefficient value of 5.031. This suggests that the Covid-19 Pandemic and budget absorption have an antagonistic connection. Accordingly, given that the other independent factors from the regression model remain constant, the beta variable (PYA) will drop by 5.031 for every unit rise in the Covid-19 Pandemic.

The negative value of the Covid-19 Pandemic coefficient for Budget Absorption is 5.031. This suggests that the Covid-19 Pandemic and budget absorption have an antagonistic connection. Accordingly, given that the other independent factors from the regression model remain constant, the beta variable (PYA) will drop by 5.031 for every unit rise in the Covid-19 Pandemic.

The coefficient value of the Covid-19 Pandemic Moderates the effect of Budget Planning for Budget Absorption of 2.251 and has a positive value. This means that each increase in the Covid-19 Pandemic moderates the effect of one unit Budget Planning, and the beta variable (PYA) will increase by 2.251 assuming that the other independent variables from the regression model are constant.

F Test

The results of performing an F test using SPSS 24 on the data to determine whether the variables Covid-19 Pandemic moderates jointly between Budget Planning and Budget Realization on Budget Absorption in Resort Police Station Bangka Tengah. The table shows that the computed F value is 467.364 and the significance level is 0.000.

A value of 2,511 is obtained for the F table by subtracting the total number of respondents from the total number of independent variables. This shows that when the significance value is less than 0.05 and the F count surpasses the F table, all independent variables have a positive and significant influence on the dependent variable.

Table 3. Anova F Test

| Model | Sum of Squares | df | Mean Square | F | Sig. |
|-------------------|-----------------------|-----------|--------------------|----------|-------------------------|
| Regression | | 5 | 1229,380 | 467,364 | .000^b |
| Residual | 6146,901 | 66 | 2,630 | | |
| Total | 173,610 | 71 | | | |

Source: Processed using SPSS

Additionally, it is determined that Budget Planning and Budget Realization are moderated by Covid-19. Covid-19's moderation of the effect of Budget realization, when combined, has a favorable and considerable impact on budget absorption. The Covid-19 Pandemic worked together to lessen the influence of Budget Planning and the effect of Budget Realization, which had a positive and significant effect on Budget Absorption at the Bangka Tengah Police Station. To determine the

direction of the positive and negative correlation between each independent variable and the dependent variable when the independent variable increases or decreases, the equation of multiple linear regression analysis, also known as multiple regression analysis, is used. The table shows the outcomes of data processing for the multiple regression statistical test.

Coefficient Determination (R²)

The coefficient of determination is a figure or index that represents the percentage of one or more variables contributing to the variation (rise/fall) of another variable (the dependent variable). As the independent variables’ coefficients of determination grows, so does their ability to impact the dependent variable. The goodness of fit measure determines how much of the variation in the dependent variable can be explained by the independent variable.

The coefficient of determination (R²) ranges from 0 to 1. The less influence all independent variables have on the value of the dependent variable, the closer a regression equation’s magnitude (R²) approaches zero, or, to put it another way, the less efficiently the model can account for variations in variable values. As a result, the model’s capacity to explain changes in the dependent variable’s value is strengthened. On the other hand, an R² value for a regression equation that is nearer to 1 denotes a higher influence of all independent variables on the dependent variable. In this inquiry, the adjusted coefficient of determination (AdjustedR Square) is applied.

Table 4. Coefficient Determination

| b. Dependent Variable: Budget Absorption | | | | | |
|--|--------------------|----------|-------------------|----------------------------|---------------|
| Model | R | R Square | Adjusted R Square | Std. Error of the Estimate | Durbin-Watson |
| 1 | 0.986 ^a | 0.973 | 0.970 | 1.62187 | 1.974 |

Based on the table, the value of the adjusted coefficient of determination (AdjustedR Square) is 0.971, meaning that the independent variable has an influence of 97.0% on budget absorption at the Bangka Tengah Police Station.

Effect of Budget Planning Variabel with Budget Absorption

It cannot be denied that a work unit will certainly try to work well and or better. The problem is whether the activity plan and budget have been prepared on the basis of needs analysis and whether the activity schedule has been calculated carefully by considering conditions at the user/field level. If these conditions have been carried out adequately, then the activities and budget should continue to run on track or there is no need to accelerate budget absorption because it will change the planned activity schedule ([Susanto & Rahayu, 2010](#))

Planning is important. Planning begins from data. Lack of historical government project records, as the impact of data availability is not effective and efficient regarding the quantity and quality of data. This is caused by the data not being centralized, collected, and maintained consistently. As for the impact, historical data are not effective in estimating the cost ([Wang et al., 2007](#)). Historical data quality would also affect estimation. Thus, incomplete information determines the success of the project, and incorrect information would lead to estimation failure (Ministry of Transportation and Infrastructure 2013; GAO, 2009). Therefore, the better the quality of the data, the better the estimation will be ([Rozalina & Mansor, 2022](#)).

This research is in line with the results of [Ratag \(2019\)](#), entitled The Effect of Budget Planning on Budget Absorption at Sam Ratulangi University, which shows that the employee budget has a statistically significant effect on the absorption of the DIPA budget. [Gusmartina et al. \(2020\)](#) showed that the variables of budget planning, budget execution for goods and services

procurement, human resource competence, and budget politics affect budget absorption in regional apparatus organizations (OPD) of the Pelalawan Regency government.

Budget planning has no significant effect on budget absorption. Problems that arise in budget planning do not occur during the preparation process and determination but due to external factors that cannot be controlled. Budget execution has a significant effect on budget execution. Delays in budget absorption occur because of budget management policies issued by the government in the current fiscal year, such as policies on using KKP as a means of payment (Handayani, 2022)

Effect of budget realization variables on budget absorption

Budget realization is also a factor affecting budget absorption. Matters in budget realization that affect both good and bad budget absorption include: a) Problems that occur internally in work units such as delays in issuing decrees for financial management personnel, financial management officials often transferred, implementation of activities not seeing the schedule in the DIPA, there are still asterisks (blocks) on the budget ceiling, delays in the appointment of the goods and services procurement committee and the absence of rewards and punishments, as well as the habit of delaying work. The reluctance of employees to be appointed as Commitment Making Officers (PPK) for the Procurement of Goods/Services is not a new problem in the internal work unit. b) Mechanism of Payment (budget disbursement) with two payment methods, namely the mechanism for direct payments to third parties (LS) or non-cash, which is currently implemented, and the mechanism through Supply Money (UP). Based on research by Putri (2022), Based on Law no. 1 (2004), the budget year for the implementation of state/regional revenues and expenditures is a fiscal year covering a period of one year, from January 1 to December 31. It can be said that if the implementation of the budget is carried out within the stipulated time, the absorption of the budget will also be better.

Influence of the Covid-19 pandemic variable on budget absorption

The Covid-19 pandemic has impacted a variety of program activities, including the contribution of women to development, budget absorption, family resilience, family economic life, and socialization of health and welfare programs, according to Kania et al. (2021). This is an example of how the Covid-19 pandemic has made it harder to perform plans and use the monies allocated. To help local governments adapt to IMR and strengthen the national economy, this research also generates policy suggestions, according to a study by Jaweng et al. (2020). The policy suggestions in this research are anticipated to assist the SDGs during the Covid-19 pandemic within the context of sustainable development without having to separate the strategy. For the coming year, sustainable development will continue to be the primary goal of program modifications and budget reallocations. According to prior theory and research, the Covid-19 pandemic certainly influenced budget absorption that was not anticipated. The way planning is done and how agreed-upon finances are used have both been negatively impacted by the Covid-19 pandemic.

According to Jaweng et al., 2020, this study also generates policy suggestions that might assist local governments in making the necessary adjustments to IMR to strengthen the national economy. It is anticipated that the policy recommendations in this study will be able to support the SDGs within the context of sustainable development during the Covid-19 pandemic without necessitating a change in the strategic focus (budget reallocation and priority targets in program adjustments), which will continue to be the direction of sustainable development. According to prior theory and research, the Covid-19 pandemic certainly influenced budget absorption that was not anticipated. According to some of these studies, the planning factor must be improved to avoid

budget delays (Syarifuddin et al., 2022).

Influence of the Covid-19 pandemic variable moderates the effect of budget planning on budget absorption

Budget planning is one of the factors that researchers want to test here with factor-forming items, some of which are revising DIPA because the available budget turns out to be not by needs, there are excess/deficient budgets in certain spending accounts so that the budget is optimized resulting in a discrepancy in a list of planned withdrawals of funds in DIPA that have been scheduled for each month of the said fiscal year. According to Nurkholis (2019), this direction is outlined in the national development plan as an elaboration of steps to achieve a protected, prosperous, intelligent, and just society and in the fields of national life: politics, social, economics, culture, as well as defense and security. Inaccurate budget planning also results in the Budget Implementation Entry Document (DIPA) having to be revised before implementation (Syahwildan & Damayanti, 2022). The DIPA revision caused the activity schedule to be adjusted, and the implementation time was delayed. Budget realization issues result from inaccurate budget preparation, which slows down the budget's absorption and accountability process. Studies support this point of view (Herriyanto, 2012), which demonstrates the effects of planning.

Influence of the Covid-19 pandemic variable moderates the effect of budget realization on budget absorption

The results suggesting that the Covid-19 Pandemic at the Bangka Tengah Police Station prevented a significant influence on budget absorption from materializing. Furthermore, it can be concluded that the research hypothesis (H5) proves that the Covid-19 Pandemic weakens realization and shows a negative and significant influence on budget absorption. Therefore, H0 is rejected and H1 is accepted, where the Covid-19 Pandemic moderates the influence of realization and has a negative and significant effect on budget absorption at the Bangka Tengah Police Station.

CONCLUSIONS

The analysis and discussion of the research data indicate that budget planning affects budget absorption when Covid-19 is used as a moderator variable in the analysis of the influence of planning and budget realization on the absorption of the budget for the work of the Resort Police Station Bangka Tenga. The absorption of the budget is influenced by the extent to which the budget is actually achieved. The Covid-19 pandemic has a significant influence on annual expenditure. The Covid-19 outbreak had a moderating effect on budget absorption due to budget planning. The Covid-19 outbreak decreased the influence of budget realization on budget absorption. This research is expected to serve as a valuable resource for agencies when making strategic decisions. Planning at the Bangka Tengah Police Station can be adapted to meet current requirements, thus improving budget use. The Bangka Tengah Police Station can improve budget absorption using monthly budget realization.

LIMITATION & FURTHER RESEARCH

For future researchers, this research is based solely on secondary data and focuses on a limited number of variables. Therefore, it is recommended that future researchers investigating budget absorption consider examining additional variables such as administrative recording and human resource competency, which have been found to influence budget absorption. In future studies, it is possible to broaden the research sample by including a larger scope, such as the Regional Police level.

REFERENCES

- Asrudi, A. (2020). Telaah Kinerja Keuangan Berbasis Value For Money. *Musamus Journal of Economics Development*, 3(1), 22–34. <https://doi.org/10.35724/feb.v3i1.3589>
- Astrajingga, R. (2013). *Definisi Perencanaan dan Anggaran*. Blogspot.Com. <https://ronyastrajingga.blogspot.com/2013/12/definisi-perencanaan-dan-anggaran.html>
- BPKP. (2011). Menyoal Penyerapan Anggaran. *Paris Review*, 1–56. <http://www.bpkp.go.id/public/upload/unit/diy/files/PARIS REV NEW/PR Ed 6kcl .pdf>
- Ferdinan, (2020). The Influence of Budget Planning and Budget Implementation on Budget Absorption with Organizational Commitment as a Moderating Variable at the Health Research and Development Agency of the Republic of Indonesia. *Journal*.
- Fauzie, S., Soeparno, W. S. I., & Pratomo, W. A. (2022). The Influence of Efficiency on Interest Rate Loan in Indonesia Banking in Regards to The Implementation of Expected Credit Losses. *Journal of Governance Risk Management Compliance and Sustainability*, 2(1), 63-67. <https://doi.org/10.31098/jgrcs.v2i1.910>
- Graham, J., & Harvey, C. (2002). How do CFOs make capital budgeting and capital structure decisions? *Journal of Applied Corporate Finance*, 15(1), 8–23.
- Gusmartina, S., Azlina, N., & Julita, J. (2021). The Effect of Budget Planning, Budget Implementation, Procurement of Goods and Services, Competence of Human Resources and Budget Politics on Budget Absorption (Empirical Study on Opd Pelalawan District). *AFEBI Accounting Review*, 6(1), 1-9. <https://doi.org/10.47312/aar.v6i01.332>
- Handayani, K. S., Sinarwati, N. K., & Rahmawati, P. I. (2022). The Effect of Budget Planning, Budget Implementation, and Human Resource Competencies on Budget Realization at Ganesha University of Education. *International Journal of Social Science and Business*, 6(3), 438-445. <https://doi.org/10.23887/ijssb.v6i3.44152>
- Hung, J.-L., & Luo, B. (2016). FinTech in Taiwan: a case study of a Bank's strategic planning for an investment in a FinTech company. *Financial Innovation*, 2(1), 1–16. <https://doi.org/10.1186/s40854-016-0037-6>
- Idrus, M., Pananrangi, A. R., & Bahri, S. (2021). Efektivitas Pengelolaan Anggaran Pada Kepolisian Resort Mamasa. *Jurnal Paradigma Administrasi Negara*, 3(1). <https://doi.org/10.35965/jpan.v3i1.599>
- Ilhamsyah, I., Wati, L. N. ., & Lestari, E. P. . (2023). The Role of Tax Incentives as A Fiscal Stimulus to The Tax Base and Income Tax Revenue Realization. *International Journal of Management, Entrepreneurship, Social Science and Humanities*, 7(1), 1–18. <https://doi.org/10.31098/ijmesh.v7i1.1633>
- Jaweng, R. N. A., Ramda, E. E., Suparman, N., Hasibuan, S. N., Mangiri, D., & Tambunan, M. (2020). Realokasi Anggaran dan Penyesuaian (refocusing Program): Tantangan dan Respons Pemerintah Daerah Hadapi Pandemi. *Unitied Cities and Local Governments Asia-Pacific (UCLG ASPAC) and APEKSI, Jakarta*.
- Kania, I., Stiaji, I. R., Astuti, R. S., Rohaeni, N., & Yudiardi, D. (2021). The Impact Of The Covid-19 Pandemic On The Implementation Of Empowering The Role Of Women In West Java. *Jurnal Analisa Sosiologi*, 10(3). <https://doi.org/10.20961/jas.v10i0.45966>
- Kementerian Keuangan. (2021). Peraturan Menteri Keuangan Republik Indonesia Nomor 22/PMK.02/2021 tentang Pengukuran dan Evaluasi Kinerjaanggaran atas Pelaksanaan Rencana Kerja dan Anggaran Kementerian Negara/Lembaga.
- Kuswoyo, I. D. (2012). *Analisis atas Faktor-Faktor yang Menyebabkan Terkonsentrasinya Penyerapan Anggaran Belanja di Akhir Tahun Anggaran (Studi pada Satuan Kerja di Wilayah KPPN Kediri)*. Universitas Gadjah Mada.

- <https://etd.repository.ugm.ac.id/penelitian/detail/52139>
- Miliasih, R. (2012). *Analisis Keterlambatan Penyerapan Anggaran Belanja Satuan Kerja Kementerian Negara/Lembaga Tahun Anggaran 2010 di Wilayah Pembayaran KPPN Pekanbaru* (Doctoral dissertation, Tidak dipublikasikan, Jakarta: FEUI).
- Nuraeni, R., & Suryana, A. (2020). Pengaruh Perencanaan Anggaran dan Evaluasi Anggaran. *Jurnal Mahasiswa Akuntansi*, 1(1), 44–63. <https://journal.stiepasim.ac.id/index.php/JMA/article/view/159/143>
- Nurkholis, K. M. (2019). Penganggaran Sektor Publik. *Penerbit Tim UB Press, Malang*.
- Putri, A., & Herawati, N. (2022). The Effect of Budget Planning, Budget Implementation and Human Resources Competency on Budget Absorption in Bukittinggi City Regional Government. *Adpebi Science Series*. <http://adpebipublishing.com/index.php/AICMEST/article/view/110>
- Rakhman, F. (2019), "Budget implementation in a risky environment: evidence from the Indonesian public sector", *Asian Review of Accounting*, Vol. 27 No. 2, pp. 162-176. <https://doi.org/10.1108/ARA-01-2018-0020>
- Ratag, W. A., Kumenaung, A. G., & Engka, D. S. M. (2021). Pengaruh Perencanaan Anggaran Terhadap Penyerapan Anggaran Di Lingkungan Iniversitas Sam Ratulangi. *Jurnal Pembangunan Ekonomi Dan Keuangan Daerah*, 20(3), 78–91. <https://doi.org/10.35794/jpekd.32800.20.3.2019>
- Republic Indonesia Law. (2004). Law Number 25 of 2004 concerning National Development Planning System. <https://peraturan.bpk.go.id/Details/40694>
- Ridzuan, M. R., & Rahman, N. A. S. A. (2021). The Deployment of Fiscal Policy in Several ASEAN Countries in Dampening the Impact of COVID-19. *Journal of Emerging Economies and Islamic Research*, 9(1), 16. <https://doi.org/10.24191/jeeir.v9i1.9156>
- Rozalina, R., & Mansor, Z. (2022). Software Cost Estimation Practices Using RASCH Measurement Model: An Indonesian Regional Government Evidence. *Journal of Governance Risk Management Compliance and Sustainability*, 2(2), 15-28. <https://doi.org/10.31098/jgrcs.v2i2.451>
- Sudaryo, Y., Haat, M. H. C., Saputra, J., Yusliza, M. Y., Muhammad, Z., & Bon, A. T. (2021, March). Factors that affect Financial Distress: An Evidence from Jakarta Stock Exchange Listed Companies, Indonesia. In *Proceedings of the 11th Annual International Conference on Industrial Engineering and Operations Management Singapore* (Vol. 7, No. 11, pp. 3844-3848).
- Susanto, A. D., & Rahayu, S. L. (2010). *Faktor-Faktor Penyebab Rendahnya Penyerapan Belanja Kementerian/Lembaga TA 2010*. <https://fiskal.kemenkeu.go.id/>. <https://fiskal.kemenkeu.go.id/kajian/2010/09/20/095054911292040-faktor-faktor-penyebab-rendahnya-penyerapan-belanja-kementerianlembaga-ta-2010>
- Suhartono, H. P. P. U. D. (2011). *Pelaksanaan Anggaran Belanja Negara (Solusi Penyerapan Anggaran Belanja Negara Yang Efisien, Efektif Dan Akuntabel)* (Doctoral dissertation, Tesis, Tidak dipublikasikan, Universitas Indonesia, Jakarta)
- Syahwildan, M., & Damayanti, I. (2022). Analisis faktor yang mempengaruhi penyerapan anggaran di Pemerintah Daerah Kabupaten Bekasi. *IKRAITH-EKONOMIKA*, 5(1), 169-176. <https://journals.upi-yai.ac.id/index.php/IKRAITH-EKONOMIKA/article/view/1734>
- Syarifuddin, S., Sjarlis, S., & Hari. (2022). The Impact of Planning, Budget Implementation, and Human Resources Competency on Budget Absorption. *Public Sector Management and Accounting Research*, 1(2). <http://revigo.org/index.php/psmar/article/view/3>
- Wang, Q., Pfahl, D., & Raffo, D. M. (Eds.). (2007). *Software Process Dynamics and Agility: International Conference on Software Process, ICSP 2007, Minneapolis, MN, USA, May 19-20, 2007, Proceedings* (Vol. 4470). Springer.

- Wati, L. N., Ispriyahadi, H., & Zakaria, D. H. (2022). The flypaper effect phenomenon of intergovernmental transfers during the Covid-19: Evidence from Indonesia. *Zbornik Radova Ekonomski Fakultet u Rijeka*, 40(2), 353-373. <https://doi.org/10.18045/zbefri.2022.2.353>
- Widanaputra, A. A., & Mimba, N. P. S. H. (2014). The influence of participative budgeting on budgetary slack in composing local governments' budget in Bali province. *Procedia-Social and Behavioral Sciences*, 164, 391-396. <https://doi.org/10.1016/j.sbspro.2014.11.093>
- Yanuriza, Y., Hasan, A., & Rasuli, M. (2019). Pengaruh Perencanaan Anggaran, Pencatatan Administrasi, Sumberdaya Manusia, Komitmen Organisasi dan Lingkungan Birokrasi terhadap Penyerapan Anggaran PNBK Kegiatan Pengamanan Objek Vital pada Satker Jajaran Polda Riau. *Jurnal Ekonomi*, 27(4), 409–423. <http://dx.doi.org/10.31258/je.27.4.p.409-423>